

# Installation Instructions

## EXD-2N

### Express® Deck Lavatory System EXD-Series

(Standard and Wall-Hung Pedestals)

Express® Decks are ADA  
and TAS compliant.



### Table of Contents

Dimensions .....	2-3
Rough-Ins .....	4-5
Installation Instructions .....	6-9
Cleaning and Maintenance .....	10
Assembly of Components .....	11
Vernatherm™ Valve Troubleshooting .....	12
Vernatherm™ Valve Repair Parts .....	13



### IMPORTANT

Read this entire installation manual to ensure proper installation, then file these instructions with the owner or maintenance department.

Flush all the water supply lines before making connections. Debris in supply lines will cause the valves to malfunction.

Turn OFF electrical power to the outlet when installing the Express® Deck.

Wall anchors used must have a minimum pull-out rating of 1,000 lbs.

Product warranties may be found under "Product Information" on our web site at [www.bradleycorp.com](http://www.bradleycorp.com).



## EXD-2N/STD and EXD-2N/WH Express® Deck Lavatory System Dimensions

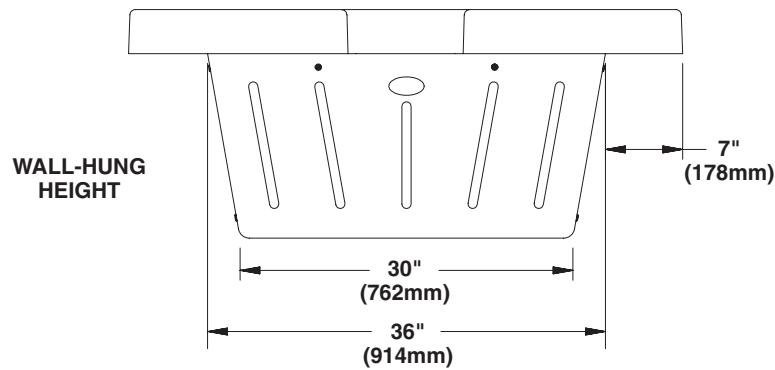
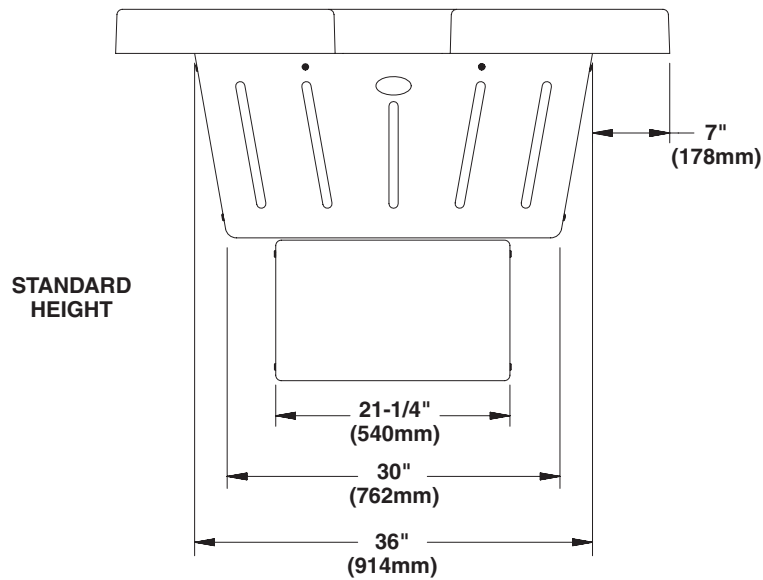
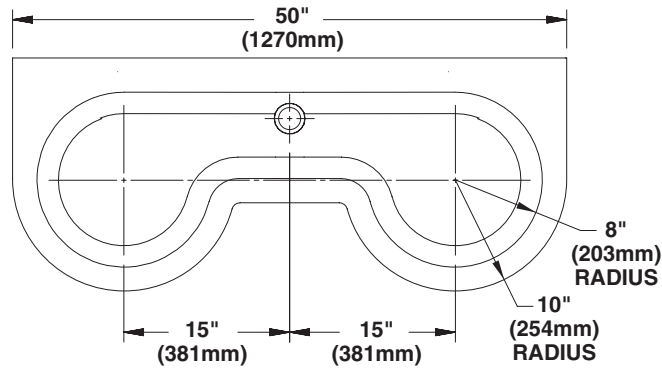

Express® Deck Lavatory System Dimensions *continued . . .*

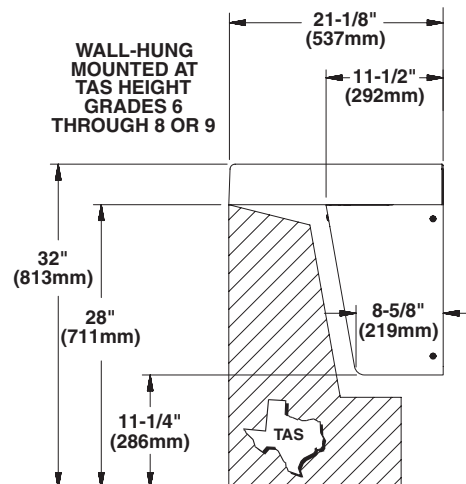
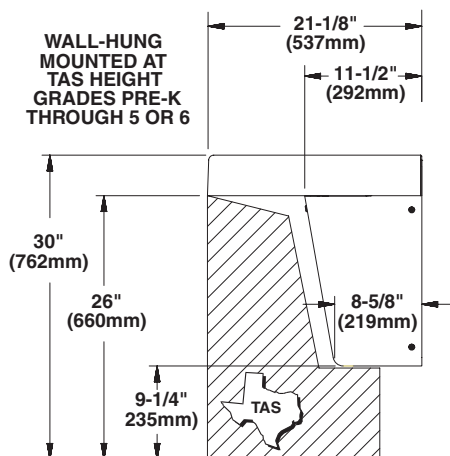
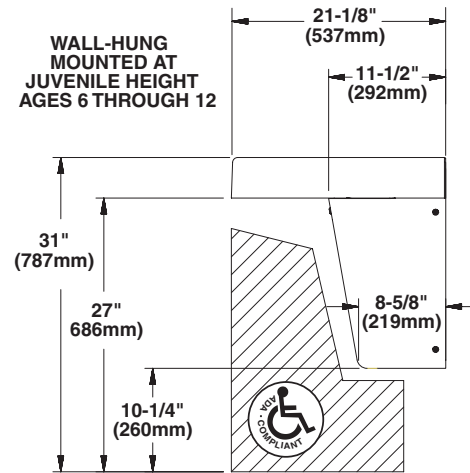
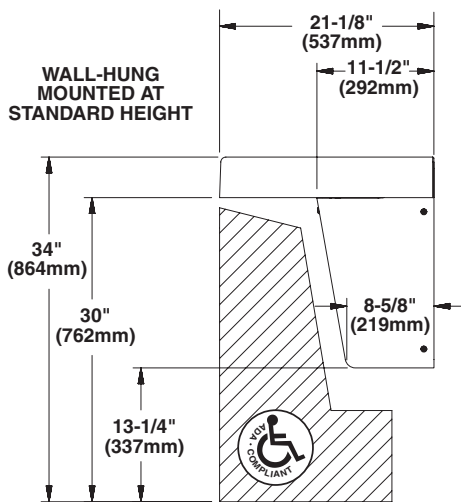
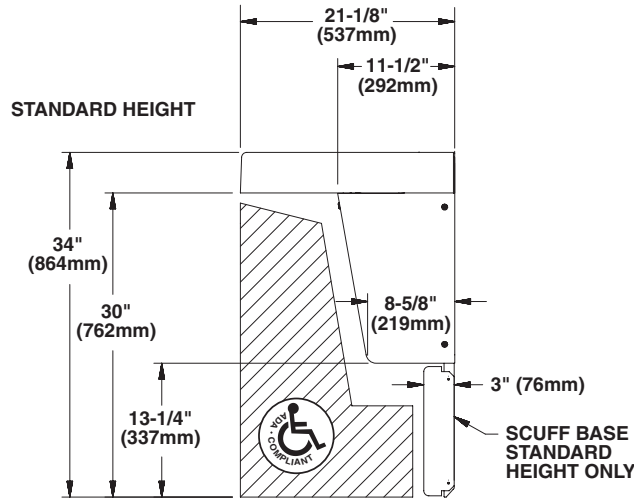

## Installation Instructions

### Supplies required for installation:

- (6) 3/8" wall anchors, bolts and 1" min. O.D. washers to mount main frame and bowl to wall (minimum pull-out rating of 1,000 lbs.)
- STD. HEIGHT ONLY: (2) 3/8" wall anchors, bolts and 1" min. O.D. washers to mount scuff base to wall
- 1/2" NPT hot and cold supply piping
- 1-1/2" NPT drain piping
- 110 volt electrical outlet for optional 110/24 VAC plug-in transformer, if required
- (2) #10 wall anchors and fasteners for optional Vernatherm™ valve mounting
- 240/208-volt or 277-volt electrical box for optional electric tankless water heater

### Step 1: Rough in



**IMPORTANT:** Dimensions shown in Figure 1 on page 5 are for a Standard and Wall-Hung Pedestal Express® Deck only. Make sure to follow appropriate dimensions based on configuration and required rim height. See Charts 1 and 2 on page 5 before beginning rough-ins.

1. Rough in 1/2" NPT hot and cold supply lines through wall at dimensions shown.
2. Rough in 1-1/2" NPT drain waste connection through wall at dimensions shown.
3. FOR OPTIONAL ELECTRIC FAUCETS: Install the 110 volt GFCI electrical outlet per local code at the location shown in Figure 1.
4. Install four to six 3/8" wall anchors with a minimum pull-out rating of 1,000 lbs. (supplied by installer) at the locations shown in Figure 1.
5. On the back of the bowl, measure the distance between the 3/4" bowl mounting holes. Divide this measurement in half. Measure and mark this dimension on the wall to the left of the centerline and to the right of the centerline. Install two 3/8" wall anchors with a minimum pull-out rating of 1,000 lbs. (supplied by installer) at the locations marked (ref. location "A" shown in Figure 1).

*NOTE: Wall anchors at location "C" (standard frame only) do not require a minimum pull-out rating of 1,000 lbs.*

*NOTE: The anchors will be used to mount the Express® Deck bowl and frame to the wall.*

# EXD-2N Express® Deck Lavatory System Dimensions

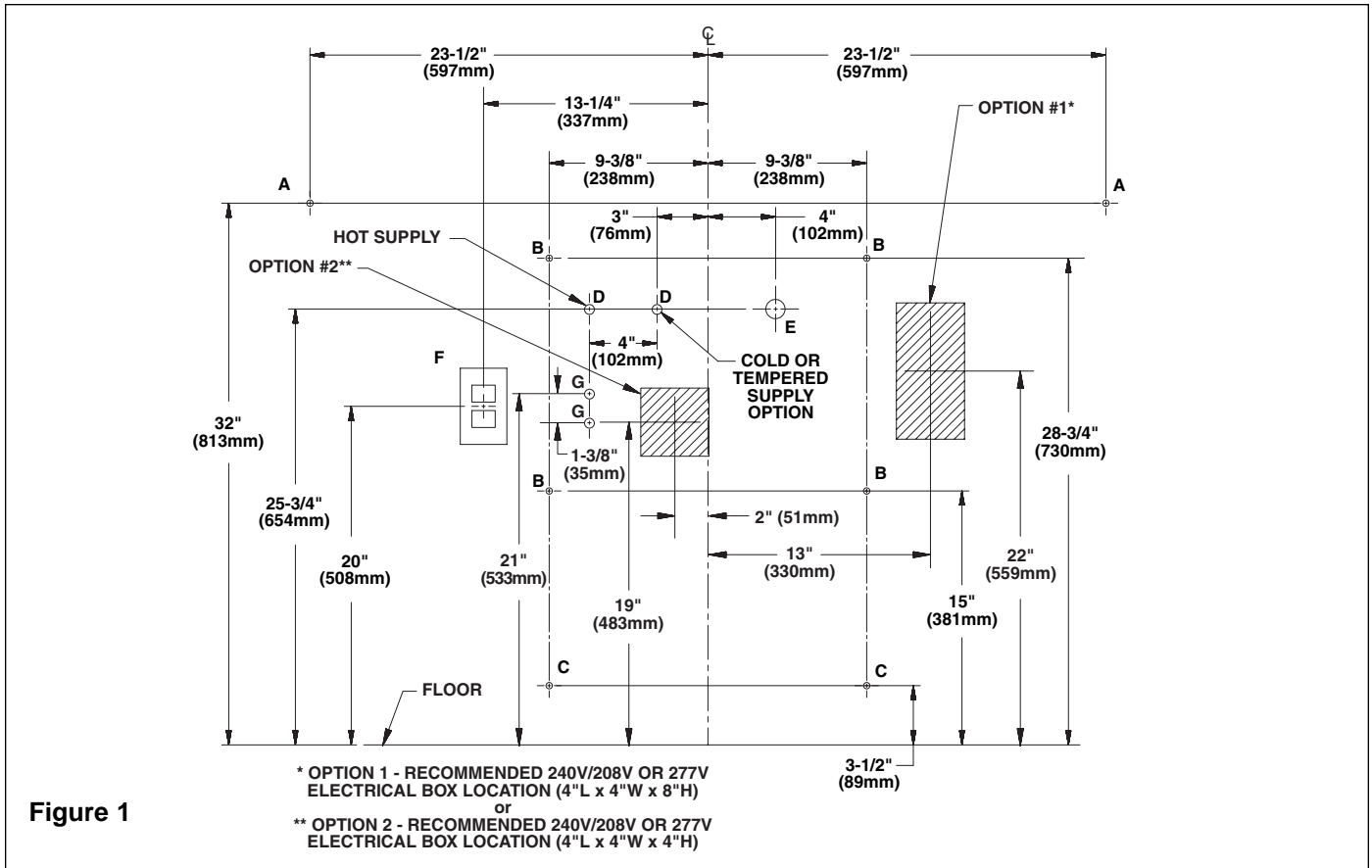

CHART 1

RIM HEIGHT	VERTICAL HEIGHT ADJUSTMENTS "A" THROUGH "F"	FIXTURE STYLE
34"	NONE	STANDARD HEIGHT
34"	NONE	WALL HUNG
32"	SUBTRACT 2"	TAS, GRADES 6 THRU 8/9
31"	SUBTRACT 3"	JUVENILE HEIGHT
30"	SUBTRACT 4"	TAS, PRE-K THROUGH 5/6

CHART 2

CODE	DESCRIPTION	QTY.
"A"	3/8" BOWL WALL ANCHORS WITH A MINIMUM PULL-OUT FORCE OF 1,000 LBS.	2
"B"	3/8" MAIN FRAME WALL ANCHORS WITH A MINIMUM PULL-OUT FORCE OF 1,000 LBS.	6
"C"	3/8" BASE FRAME WALL ANCHORS, STANDARD FRAME OPTION ONLY.	2
"D"	1/2" NPT HOT/COLD SUPPLIES, STUB OUT 2" FROM WALL	2
"E"	1-1/2" NPT DRAIN, STUB OUT 2" FROM WALL	1
"F"	110V GFCI PROTECTED ELECTRIC OUTLET (FOR OPTIONAL ELECTRONIC FAUCETS)	1
"G"	#10 WALL ANCHORS/FASTENERS FOR OPTIONAL VERNATHERM™ VALVE MOUNTING	2

## Installation Instructions *continued* . . .

### Step 2: Mounting frame to wall

1. Using a T20 Torx key, remove the six #10-24 flat head Torx screws and #10 finish washers securing the access panel to the main frame, and remove the panel (Figure 2).
2. Position the frame against the wall, ensuring that it is level.



**IMPORTANT: Anchoring the frame to a wall that is *not* flat may cause the frame to bend, making it difficult to reinstall the access panels.**

3. Ensure that the back of the frame is flat against the wall.

4. Once you have positioned the frame such that it is level (and resting on the floor, standard height frame only) and flat against the wall, use the 3/8" bolts and 1" min. O.D. washers to mount the frame to the wall (Figure 3).

5. When mounting the standard height frame, mount the scuff base to the wall at the same time using the two additional 3/8" bolts and washers mentioned in Step 1, procedure #3 on page 4 (Figure 3).

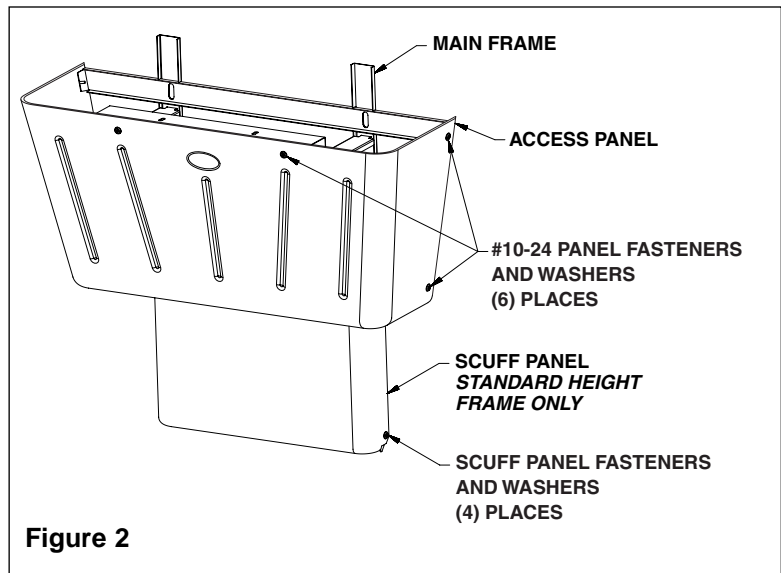

Figure 2

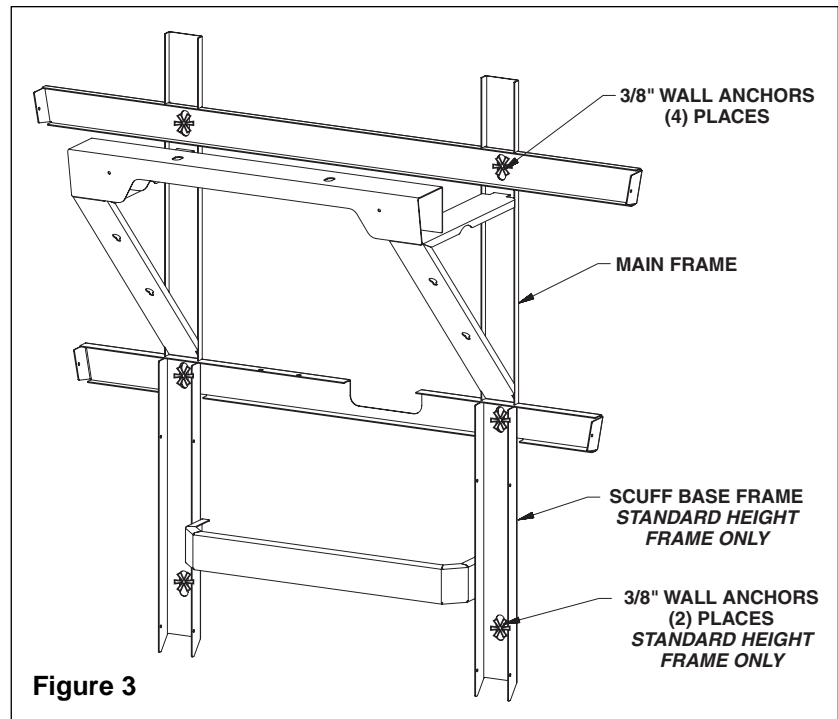

Figure 3

## Installation Instructions *continued* . . .

### Step 3: Installing bowl

**⚠ WARNING:** To prevent serious injury and/or damage to the bowl, move and position the bowl with the assistance of another person and always use appropriate lifting procedures.

*NOTE:* Refer to Figure 4 below when installing the bowl.

1. With someone to assist you, place the bowl squarely onto the frame.
2. Attach the front underside of the bowl to the frame using the two 1/4"-20 x 1/2" pan-head screws and washers provided. **Do not tighten bolts at this time.**

**⚠ IMPORTANT:** When bolting the bowl to the frame and wall, do not overtighten bolts. Overtightening bolts can damage the Terreon® material.

3. After the bowl is attached to the frame, use 3/8" bolts and 1" min. O.D. washers (supplied by the installer) to bolt the bowl to the wall anchors, two places.
4. Tighten the screws installed in procedure #2 above to secure the bowl to the frame. **Do not overtighten.**

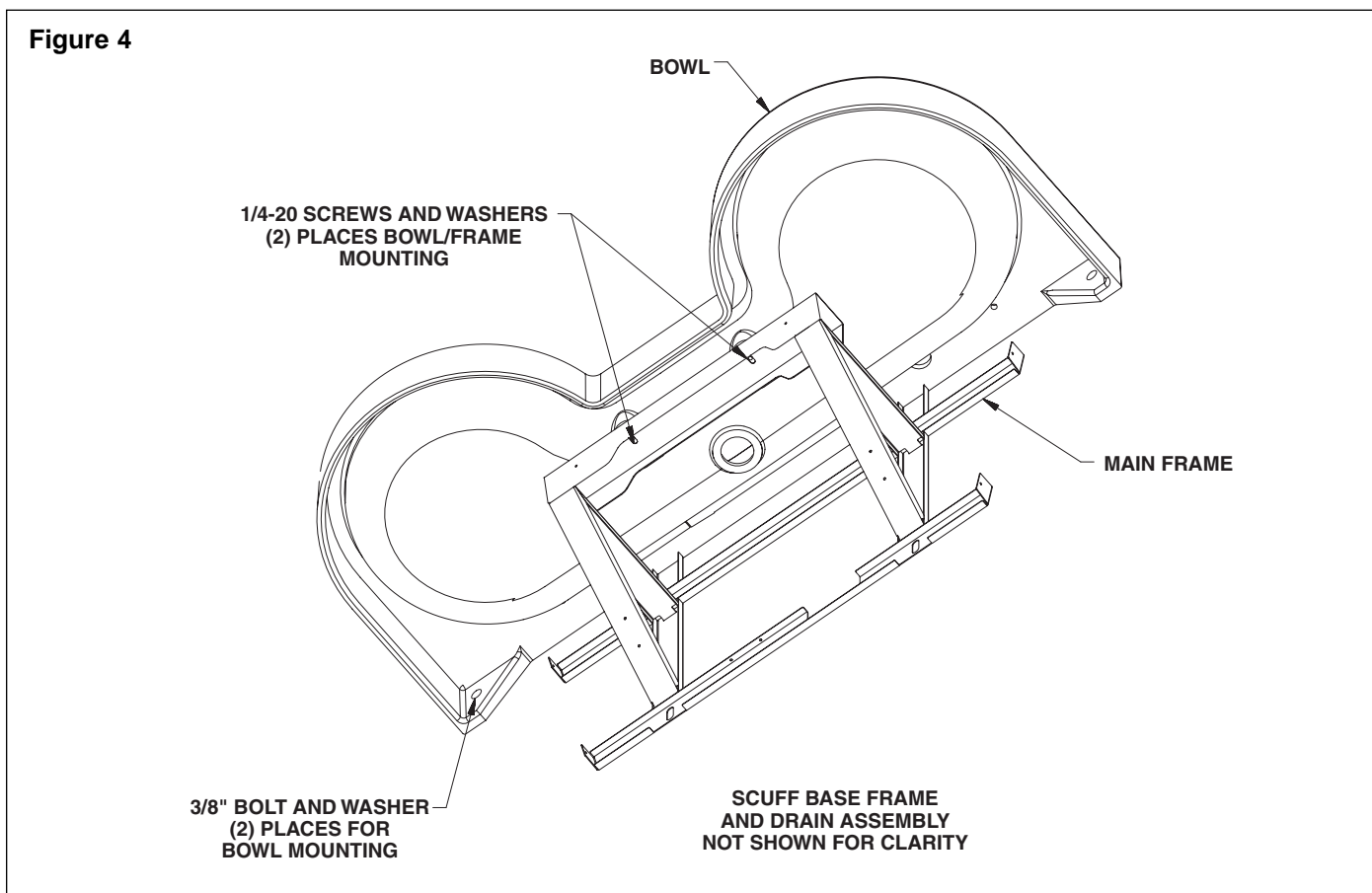

## Installation Instructions *continued* . . .

### Step 4: Connecting supply and drain

1. Connect the Vernatherm™ Thermostatic Mixing Valve as shown in Figure 5a.
2. Install the drain plug in the drain hole in the bowl (see Figure 5b).
3. Beneath the bowl, install the 1/8" rubber washer and the threaded tailpiece onto the drain plug.
4. Assemble the P-trap by connecting the 1-1/2" tubular pipe to the tailpiece and to the 1-1/2" drain pipe stubbed out of the wall (see Figure 5c).
5. Install the strainer on the drain plug opening inside the bowl using the #8 screw.

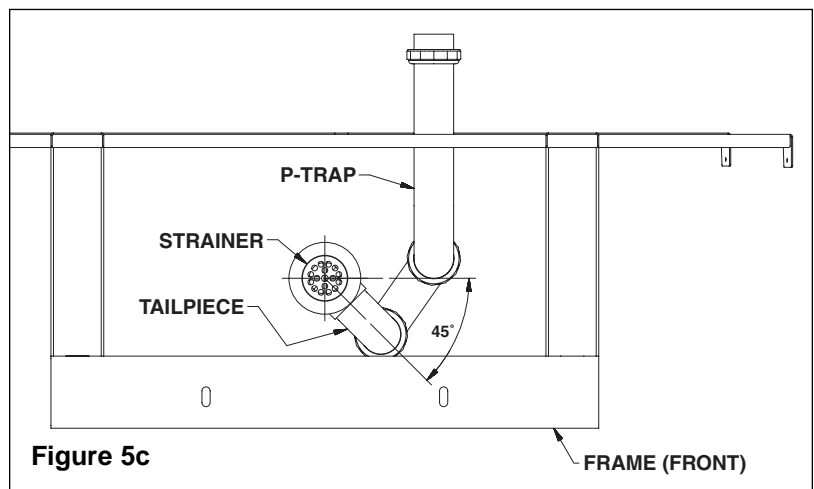
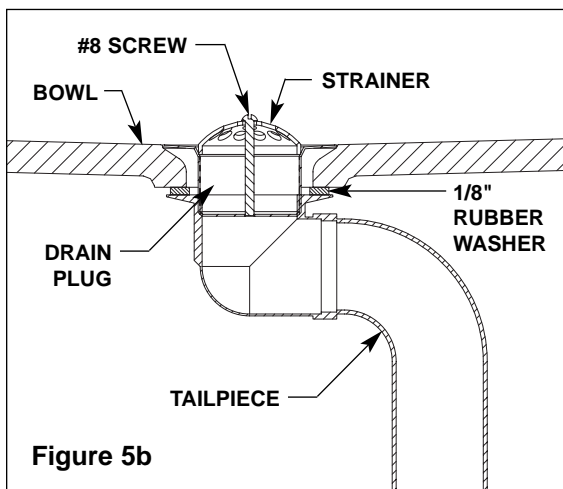
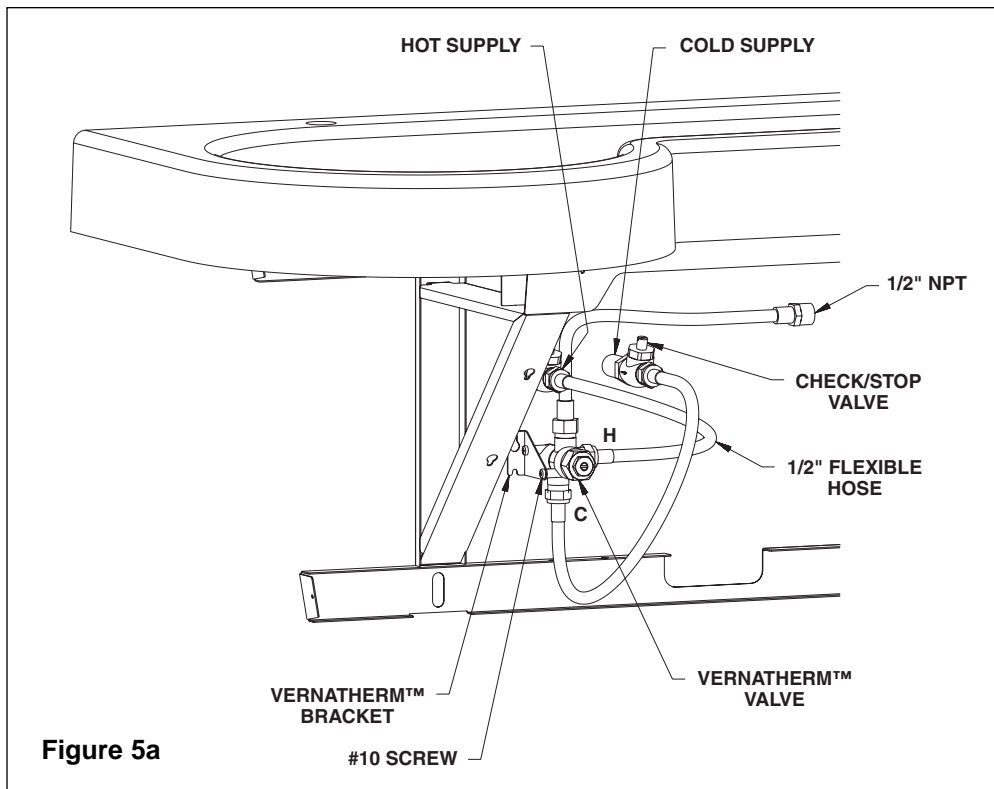



## Installation Instructions *continued* . . .

### Step 5: Optional hot water heater

**⚠ WARNING:** To avoid personal injury or damage to the unit when installing the water heater, make all plumbing connections first, then proceed with the electrical connections.

*NOTE: 240/208 or 277 voltage is required for hot water heater. Refer to the installation manual provided with the hot water heater for further installation information.*

1. Remove the cover from the water heater. Attach the bracket to the cover with the two screws, nuts and washers, then reattach the cover (see Figure 6a).
2. Hang the water heater on the right side frame member (see Figure 6b).
3. Connect the 1/2" flexible hose from the cold water supply stub-out to the hot water heater inlet.
4. Connect the 1/2" flexible hose from the hot water heater outlet to the supply inlet on the solenoid valve assembly.

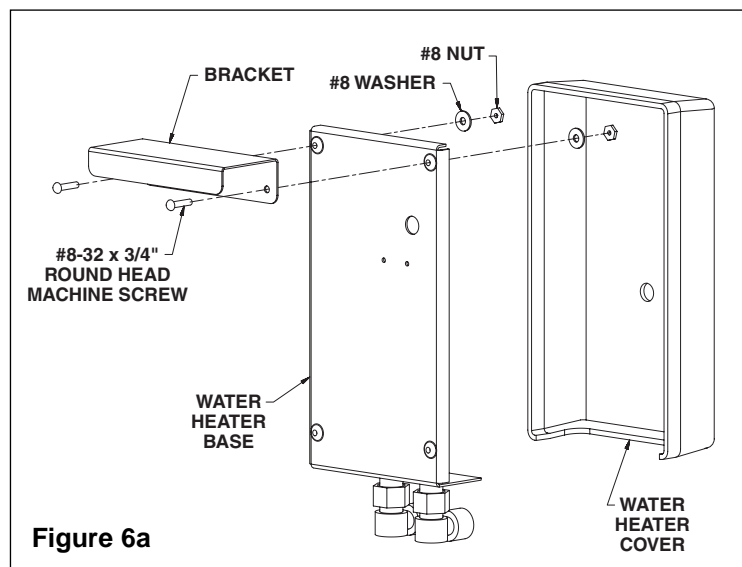

### Step 6: Completing installation

1. Install the faucets according to the installation instructions that came with your faucets.
2. Turn on the water supply to the Express® Deck and check for leaks.
3. **FOR DECKS WITH INFRARED FAUCETS ONLY:** Turn on the electrical power to the electrical outlet and pass your hand in front of each faucet's sensor until all the air is purged from the lines and water is flowing smoothly.
4. After testing is complete, reinstall panel to frame. Fasten panel with eight Torx-head screws provided (see Figure 2 on page 6).

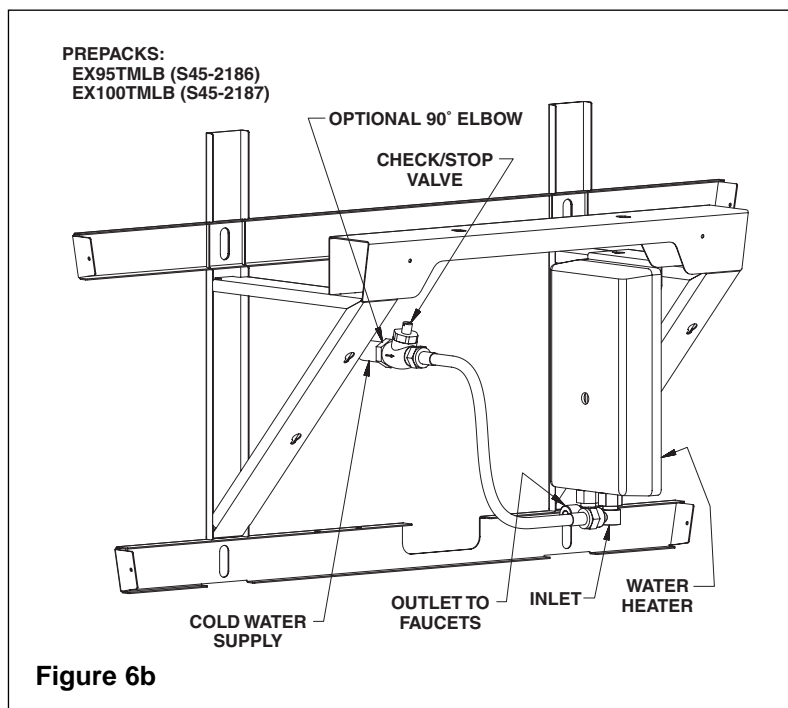

## Cleaning and Maintenance Instructions



**IMPORTANT:** Strong alkaline or acid-based chemicals and cleansers should not be used to clean Terreon®. If these chemicals come in contact with the Terreon® surface, wipe off the surface immediately and flush with soapy water.

### Terreon® and panel maintenance

The bowl is constructed of Terreon®, a densified solid surface material composed of an acrylic modified polyester resin. Terreon® is resistant to chemicals, stains, burns and impact. Surface damage can be easily repaired with everyday cleaners or fine grit abrasives. The panel is made of an acrylic/ABS laminate, and will not chip, peel or flake. With regular cleaning, your Terreon® fixture will provide years of dependable service.

### Cleaning

- **Daily Cleaning:** Wipe the surface with a damp cloth and wipe dry.
- **Weekly Cleaning:** Wipe the surface with a damp cloth and a household liquid detergent. Stubborn stains can be removed as follows:
  1. Using a #7448 Scotch-Brite® pad, scrub with an abrasive cleanser such as Ajax®, Comet® or Soft Scrub® and water.
  2. Clean thoroughly with soapy water and allow to dry.
- **Scorch Marks:** Although Terreon® will not burn, a lit cigarette in contact with Terreon® could leave a scorch mark. Scorch marks can be removed by buffing with a #7448 Scotch-Brite pad or with an abrasive cleaner.
- **Repair kit:** In the unlikely event your Terreon® surface becomes damaged, it can easily be repaired. Contact your Bradley representative to order a repair kit and be sure to specify color when ordering.

### Panel cleaning



**IMPORTANT:** Do not use abrasive cleansers to clean the panel. Abrasive cleaners can mar the surface.

- **Graffiti/Vandalism:** If vandals create markings on the panel, Bradley recommends using Motsenbocker's LIFT OFF® to remove ink and spray paint. Remover #3 is for ink and markers, and Remover #4 is for spray paint. Motsenbocker's LIFT OFF® can be ordered through Sanitary Maintenance Service Inc. (call 1-800-451-5523 x 425 or visit [www.sanitarymaintenance.com/product.htm](http://www.sanitarymaintenance.com/product.htm) for ordering information). After cleaning with LIFT OFF®, give the panel a final thorough cleaning with a liquid tub and tile cleaner to remove soil and maintain the glossy finish.

*NOTE: Use of brand names is intended only to indicate a type of cleaner. This does not constitute an endorsement, nor does the omission of any brand name cleaner imply its inadequacy. Many products named are regional in distribution and can be found in local supermarkets, department and hardware stores or through your cleaning service. It is emphasized that all products should be used in strict accordance with package instructions.*

# Assembly of Components

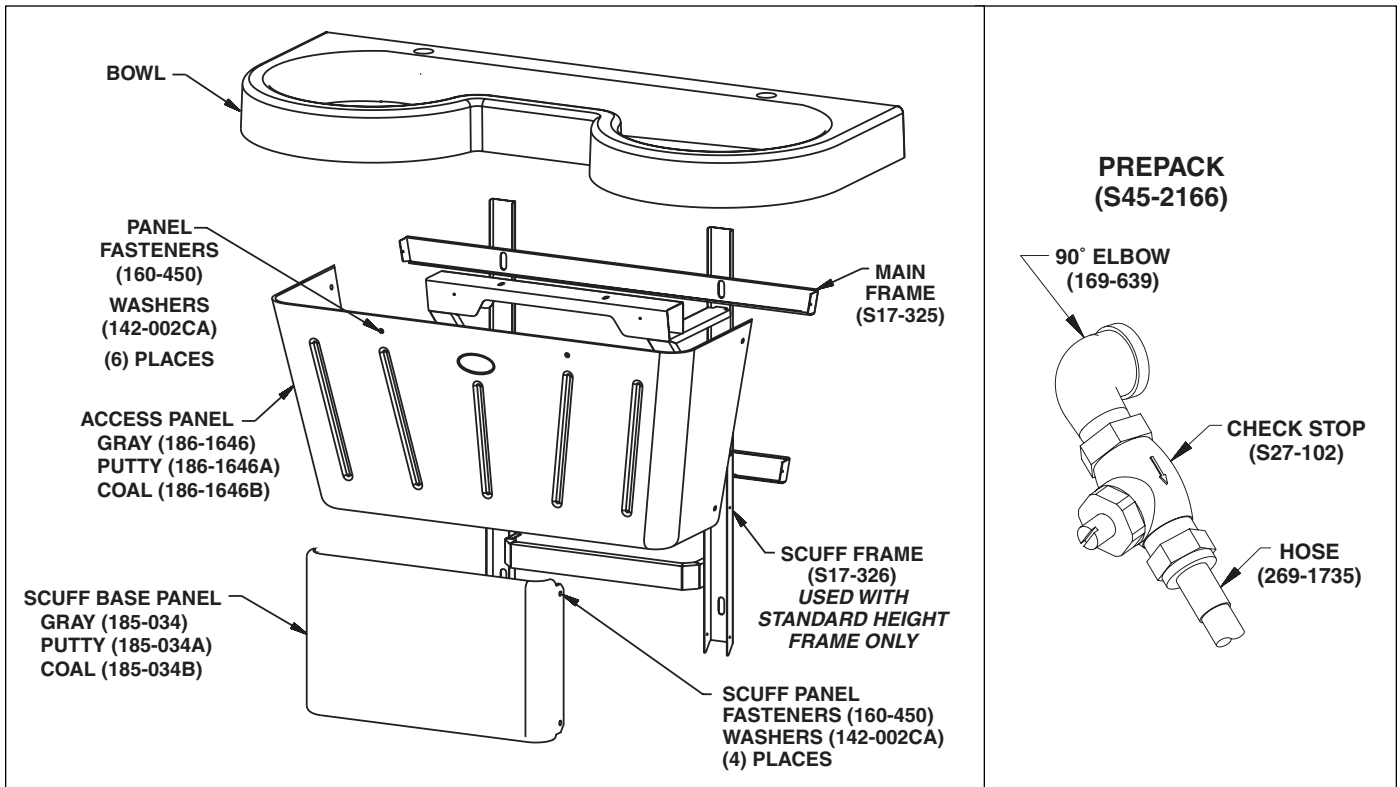

## BOWL MOUNTING HARDWARE

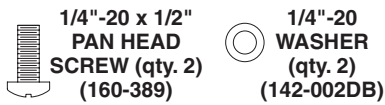

## DRAIN ASSEMBLY

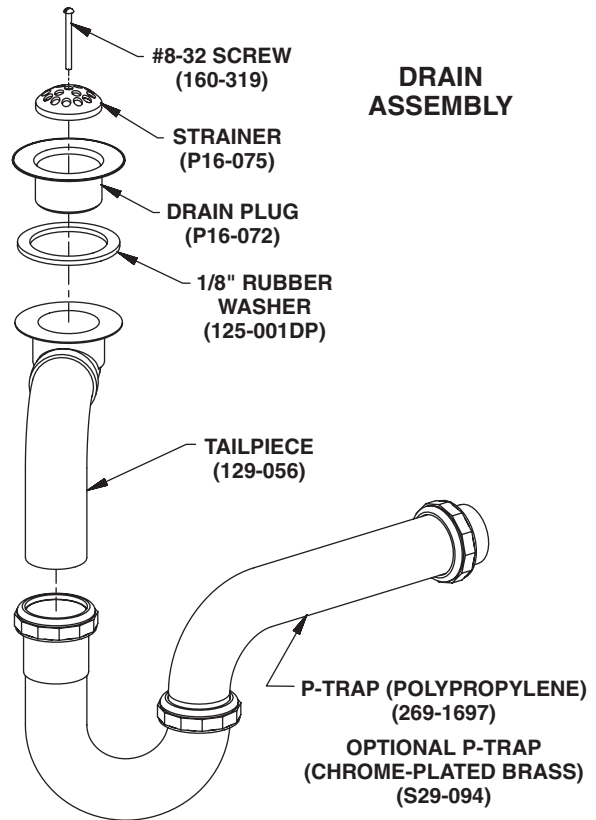

## VERNATHERM™ VALVE ASSEMBLY

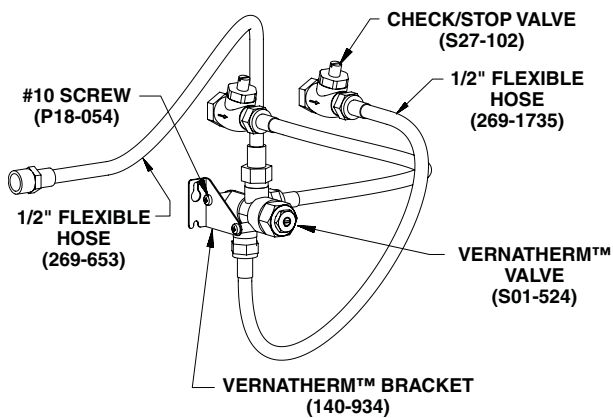

## Thermostatic Mixing Valve Maintenance and Troubleshooting

*NOTE: Before attempting to troubleshoot the valve or disassemble the components, check for the following conditions:*

- *If stop/check valves are used, make sure that they are fully open.*
- *Make sure that the hot and cold inlet pipes are connected properly, and that there are no cross-connections or leaking stop/check valves.*
- *Check the hot water heater output to make sure that it is at least 20° F above the set temperature.*

*Be sure to close the appropriate shut-off valves prior to disassembly of the valve and reopen the valves after inspection and repair is complete.*

### **Problem: Limited water flow**

*Cause: Dirt and debris have built up in the valve or strainer.*

1. Remove and clean strainer. If strainer needs to be replaced, order Bradley part no. 173-028.
2. Check the piston for smooth movement.

To check the valve's piston for free and smooth movement, follow the procedures outlined below:

1. Remove the valve's cap and thermostat (see Figure 7 on Page 13).
2. Push down on the piston with your finger (the piston should move freely). If the movement is not as it should be, the piston needs to be cleaned. Follow the method outlined below for cleaning the piston and valve body:
  - Remove the thermostat.
  - Lift the piston out with a needle-nose pliers and remove the spring.
  - Any cleaner suitable for brass and stainless steel may be used (if cleaning with suitable cleaner is not sufficient to remove debris, a 400-grit sandpaper may be used to polish and hone the piston and valve body).
  - Snap spring into piston (will detent) and reassemble into the valve body. Retest the piston.
3. If, after a thorough cleaning, the piston does not move freely, the piston must be replaced. Contact your Bradley representative and ask for Repair Kit (part number S65-259).

### **Problem: External leaks in the system**

*Cause: O-rings have been damaged.*

**Solution:** Replace O-rings where necessary. For replacement of the O-rings, contact your Bradley representative and ask for Repair Kit (part number S65-259).

### **Problem: Improper water temperature or temperature fluctuation**

*Cause: Thermostat is slowly failing or not working at all.*

**Solution:** Check the thermostat for proper operation.

1. At room temperature (80° F or less) remove cap and thermostat.
2. Place thermostat into container with 115° F water. The pushrod should pop out of the thermostat approximately 1/10".
3. If thermostat pushrod does not pop out, the thermostat must be replaced. Contact your Bradley representative and ask for Repair Kit (part number S65-259).

*Cause: Valve temperature is not properly set.*

**Solution:** Adjust the temperature. Using a blade screwdriver, turn the adjustment stem **counterclockwise** to **increase** the temperature or **clockwise** to **decrease** the temperature.

# Vernatherm™ Thermostatic Mixing Valve S01-524

## Repair Kit S65-259

Item	Qty	Description
5	1	Thermostat
7	1	O-Ring
8	1	O-Ring

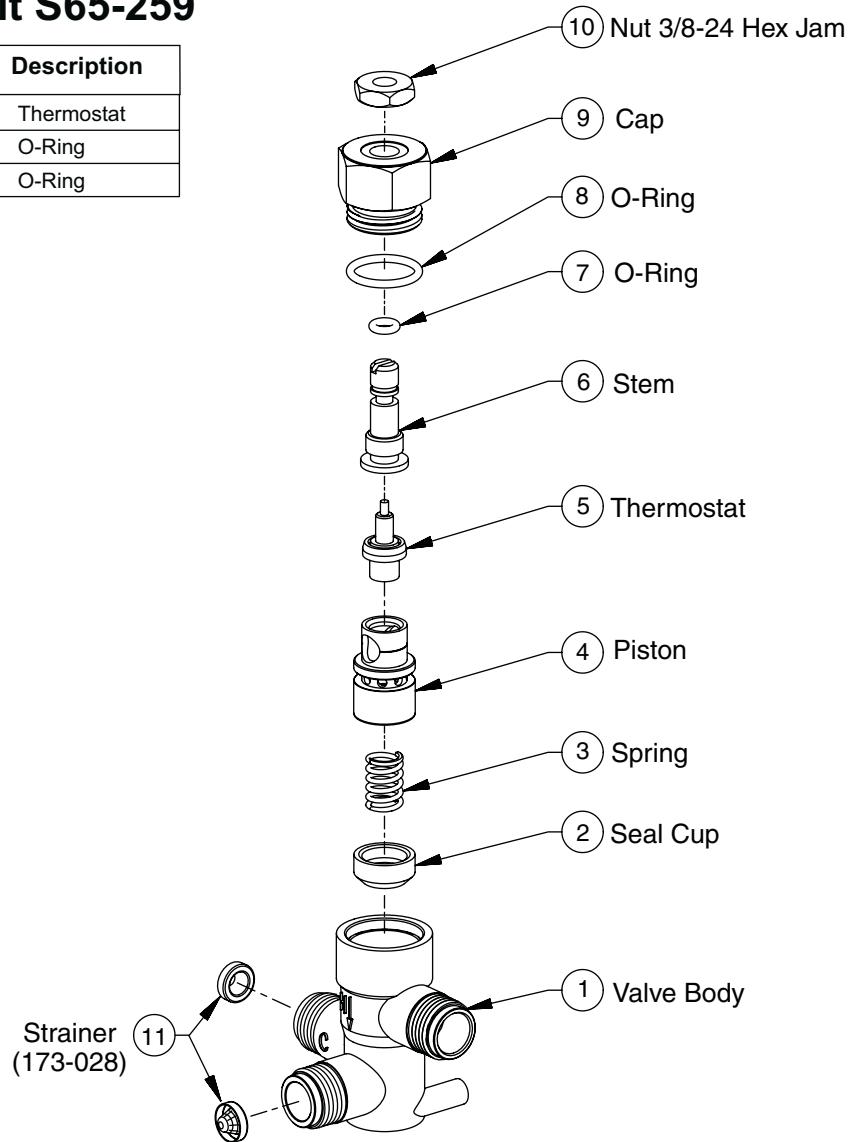

Figure 7